

■ Inrush current limiter

Power Thermistor

Power thermistors utilize the self heating characteristic of NTC thermistors which causes a significant decrease in resistance in a short time. Power thermistors can be used instead of inrush current limiting resistors. Power thermistors have the advantage that their resistance decreases through self heating which reduces power loss and results in energy savings.
UL1434 File No. E92669 (1D2-22 excluded) certified.

■ Product number explanation

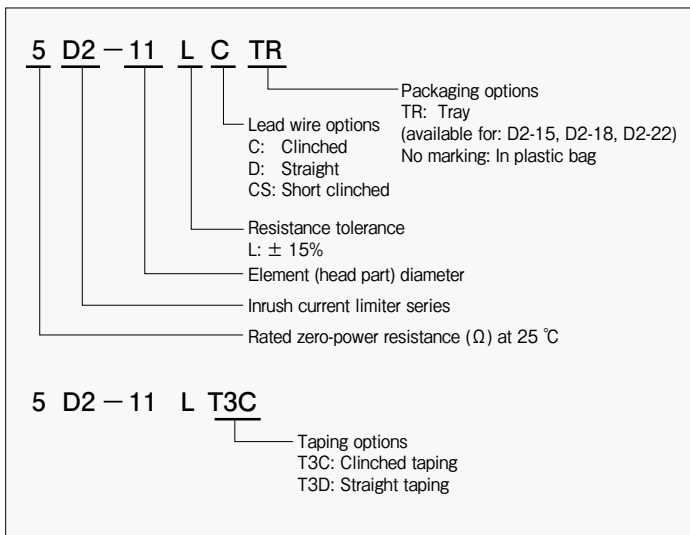

■ Applications

Switching power supplies, adapters, LCD TVs, plasma TVs, air conditioners, DVD players, audio equipment, LCD projectors, copiers, PCs, printers, office automation equipment, gaming machine power supplies

■ Dimensions

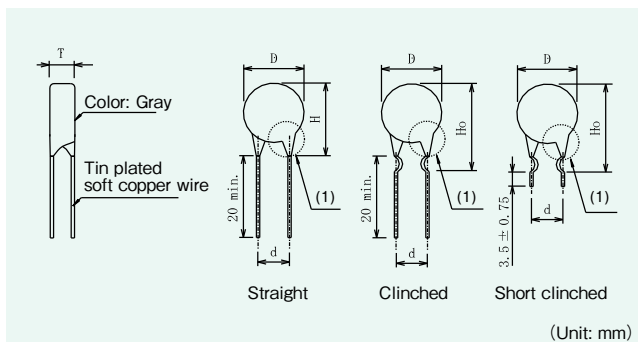

(1): Do not apply force to the lead wire legs from the side as this may damage the power thermistor.

	D	T	H	H0	d	Lead wire diameter
D2-05	8.5 max.	7.0 max.	11.5 max.	15.5 max.	5.0 ± 1	Φ 0.8
D2-07	11.0 max.	9.0 max.	13.0 max.	16.0 max.		
D2-08	10.0 max.	7.0 max.	13.0 max.	17.0 max.		
D2-10	13.0 max.	9.0 max.	17.0 max.	19.5 max.		
D2-11	11.5 max.	8.0 max.	15.0 max.	18.5 max.	7.5 ± 1	
D2-13	14.5 max.	8.0 max.	18.0 max.	21.5 max.		
D2-14	17.0 max.	9.0 max.	21.0 max.	22.5 max.		
D2-15	16.5 max.	8.0 max.	20.0 max.	23.0 max.	10 ± 1	Φ 1.0 (Φ 0.8)
D2-18	19.5 max.	8.0 max.	23.0 max.	26.0 max.		
D2-22	23.0 max.	8.5 max. (8.0 max.)	26.5 max.	29.5 max.		

1: D2-22

Unit: mm

■ Taping dimensions

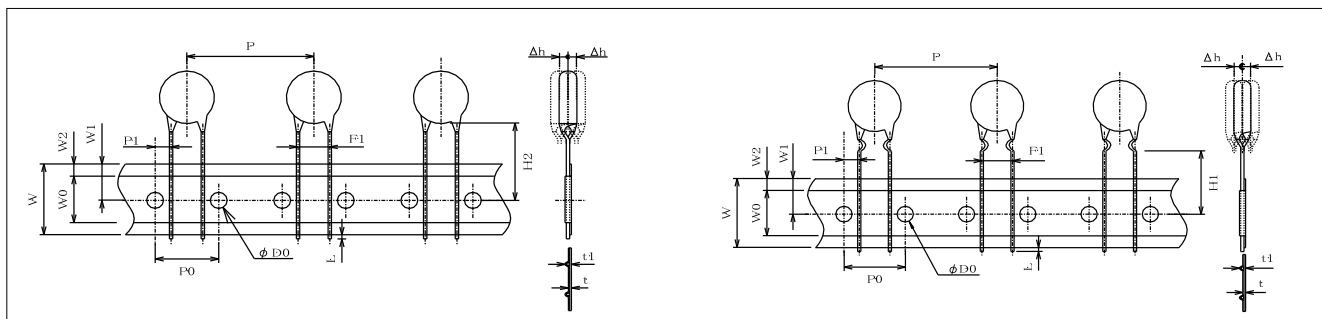

	P	P0	P1	W	W0	W1	W2	H1	H2	L	F1	ΦD0	t	t1	Δh		
D2-05	15.0 ± 1.0	15.0 ± 0.3	5.0 ± 0.7	17.5 to 19.0 min. 5.0	9.0 ± 0.5	max.3.0	16.0 ± 0.5	19.0 to 21.5	max. 1.0		5.0 ± 0.5	4.0 ± 0.2	0.6 ± 0.3	max. 1.5	0 ± 2.0		
D2-07																	
D2-08																	
D2-10																	
D2-11	30.0 ± 1.0		3.75 ± 0.7								7.5 ± 0.5						
D2-13																	
D2-14																	

• MOQ: 1000 pcs.

Unit: mm

Specifications

Product number	Zero-power resistance at 25 °C (± 15%)	B value ¹		Max. current at 25 °C	Residual resistance (Ω)	Thermal time constant ² (s)	Dissipation factor (mW / °C)	Operating temp. range (°C)	Max. capacitance				Energy surge capacity (J)
		B _{25/85}							AC	AC	AC	AC	
		(± 5%)	(K)						100 V	120 V	220 V	240 V	
5D2-05	5.0	2650		2.0	0.48	20	15	- 50 to 150	860	600	170	150	4.3
10D2-05	10.0	2700		1.0	0.91	20	7	- 50 to 150	860	600	170	150	4.3
20D2-05	20.0	2800		0.3	1.66	20	1	- 50 to 150	860	600	170	150	4.3
5D2-07	5.0	2800		3.0	0.36	35	30	- 40 to 160	400	260	80	60	1.9
8D2-07	8.0	2800		2.0	0.58	41	30	- 40 to 160	560	360	110	90	2.6
10D2-07	10.0	2800		2.0	0.72	45	30	- 40 to 160	680	470	140	110	3.3
12D2-07	12.0	2900		1.7	0.78	41	30	- 40 to 160	380	260	80	60	1.9
16D2-07	16.0	2900		2.0	1.04	45	30	- 40 to 160	800	530	160	130	3.8
22D2-07	22.0	2900		1.0	1.43	50	30	- 40 to 160	960	630	190	150	4.5
5D2-08	5.0	2700		3.0	0.35	35	22	- 50 to 170	1260	880	260	220	6.3
10D2-08	10.0	2800		2.0	0.63	35	17	- 50 to 170	1260	880	260	220	6.3
15D2-08	15.0	2800		2.0	0.94	35	26	- 50 to 170	2880	2000	590	500	14.0
20D2-08	20.0	2900		1.0	1.13	35	8	- 50 to 170	2880	2000	590	500	14.0
2D2-10	2.0	2800		5.0	0.15	50	32	- 40 to 160	640	1100	330	270	7.9
3D2-10	3.0	2800		4.0	0.22	53	32	- 40 to 160	720	1170	350	290	8.4
5D2-10	5.0	2900		4.0	0.33	53	32	- 40 to 160	440	970	290	240	7.0
8D2-10	8.0	2900		3.0	0.52	70	32	- 40 to 160	560	1070	320	260	7.7
10D2-10	10.0	2900		3.0	0.65	75	32	- 40 to 160	1640	1100	330	270	7.9
12D2-10	12.0	3000		1.8	0.71	53	32	- 40 to 160	830	580	170	140	4.1
16D2-10	16.0	3000		1.6	0.94	70	32	- 40 to 160	830	580	170	140	4.1
2D2-11	2.0	2650		5.0	0.15	40	26	- 50 to 170	2700	1880	550	470	13.0
3D2-11	3.0	2650		4.0	0.22	40	24	- 50 to 170	4830	3360	990	840	24.0
4D2-11	4.0	2700		4.0	0.28	40	31	- 50 to 170	2880	2000	590	500	14.0
5D2-11	5.0	2700		4.0	0.35	40	39	- 50 to 170	2700	1880	550	470	13.0
8D2-11	8.0	2800		3.0	0.50	40	31	- 50 to 170	2700	1880	550	470	13.0
10D2-11	10.0	2800		3.1	0.63	40	42	- 50 to 170	2880	2000	590	500	14.0
12D2-11	12.0	2800		2.0	0.75	40	21	- 50 to 170	4030	2800	830	700	20.0
15D2-11	15.0	2950		2.5	0.80	40	34	- 50 to 170	2880	2000	590	500	14.0
16D2-11	16.0	2950		2.5	0.86	40	37	- 50 to 170	2880	2000	590	500	14.0
20D2-11	20.0	3000		2.0	1.02	40	28	- 50 to 170	2880	2000	590	500	14.0
1D2-13	1.0	2650		6.0	0.06	55	12	- 50 to 200	860	600	170	150	4.3
2D2-13	2.0	2700		6.0	0.10	55	21	- 50 to 200	860	600	170	150	4.3
4D2-13	4.0	2800		5.0	0.18	55	24	- 50 to 200	860	600	170	150	4.3
4.7D2-13	4.7	2900		5.0	0.18	55	26	- 50 to 200	2700	1880	550	470	13.0
5D2-13	5.0	2900		5.0	0.19	55	27	- 50 to 200	2700	1880	550	470	13.0
8D2-13	8.0	3000		4.0	0.27	25	25	- 50 to 200	2880	2000	590	500	14.0
10D2-13	10.0	3050		4.0	0.32	55	29	- 50 to 200	2880	2000	590	500	14.0
12D2-13	12.0	3000		4.0	0.41	55	37	- 50 to 200	4830	3360	990	840	24.0
15D2-13	15.0	3050		3.0	0.48	55	25	- 50 to 200	4830	3360	990	840	24.0
16D2-13	16.0	3050		3.0	0.51	55	26	- 50 to 200	4830	3360	990	840	24.0
2D2-14	2.0	2800		5.0	0.15	90	36	- 40 to 160	4200	2890	860	720	20.8
3D2-14	3.0	2900		5.0	0.20	80	36	- 40 to 160	3080	2110	630	520	15.2
4D2-14	4.0	2900		5.0	0.26	95	36	- 40 to 160	3400	2350	700	580	16.9
5D2-14	5.0	2900		4.0	0.33	110	36	- 40 to 160	3600	2480	740	620	17.9
8D2-14	8.0	3000		2.5	0.47	80	36	- 40 to 160	1390	970	280	240	6.9
10D2-14	10.0	3000		2.2	0.59	95	36	- 40 to 160	1790	1240	370	310	8.9
12D2-14	12.0	3000		2.0	0.71	105	36	- 40 to 160	2190	1520	450	380	10.9
16D2-14	16.0	3000		1.8	0.94	115	36	- 40 to 160	2790	1940	570	480	13.9
1D2-15	1.0	2650		8.0	0.06	70	22	- 50 to 200	6910	4800	1420	1200	34.0
1.5D2-15	1.5	2650		8.0	0.08	70	29	- 50 to 200	6910	4800	1420	1200	34.0
2D2-15	2.0	2700		8.0	0.10	70	37	- 50 to 200	6910	4800	1420	1200	34.0
3D2-15	3.0	2800		7.0	0.13	70	36	- 50 to 200	4030	2800	830	700	20.0
4D2-15	4.0	2800		7.0	0.18	70	48	- 50 to 200	4030	2800	830	700	20.0
4.7D2-15	4.7	2900		6.0	0.18	70	37	- 50 to 200	4030	2800	830	700	20.0
5D2-15	5.0	2900		6.0	0.19	70	39	- 50 to 200	4030	2800	830	700	20.0
8D2-15	8.0	3000		5.0	0.27	70	39	- 50 to 200	4030	2800	830	700	20.0
10D2-15	10.0	3000		5.0	0.34	70	49	- 50 to 200	5760	4000	1190	1000	28.0
12D2-15	12.0	3050		5.0	0.39	70	54	- 50 to 200	5760	4000	1190	1000	28.0
15D2-15	15.0	3100		4.0	0.45	70	41	- 50 to 200	5760	4000	1190	1000	28.0
16D2-15	16.0	3100		4.0	0.48	70	44	- 50 to 200	5760	4000	1190	1000	28.0
4D2-18	4.0	2900		8.0	0.16	90	59	- 50 to 200	6910	4800	1420	1200	34.0
5D2-18	5.0	2950		8.0	0.18	90	66	- 50 to 200	6910	4800	1420	1200	34.0
8D2-18	8.0	3050		6.0	0.26	90	53	- 50 to 200	6910	4800	1420	1200	34.0
10D2-18	10.0	3100		6.0	0.30	90	62	- 50 to 200	6910	4800	1420	1200	34.0
47D2-18	47.0	3450		2.0	0.94	90	21	- 50 to 200	6910	4800	1420	1200	34.0
1D2-22	1.0	2900		12.0	0.04	125	32	- 50 to 200	8200	-	1700	-	41.0
3D2-22	3.0	2800		8.0	0.13	130	48	- 50 to 200	12600	8800	2610	2200	63.0
4D2-22	4.0	2900		8.0	0.16	130	59	- 50 to 200	12600	8800	2610	2200	63.0
6D2-22	6.0	3000		6.0	0.21	130	43	- 50 to 200	12600	8800	2610	2200	63.0

¹: In part reference values ²: Reference values

Reliability data

Item	Test conditions	Criteria
Resistance to soldering heat	10 s at 260 °C 5 s at 350 °C	ΔR ± 15%
Solderability	3 s at 245 °C Flux material: Rosin 25%, ethyl alcohol 75%	More than 95% soldered
Tensile strength (lead wire)	A load of 10 N is applied to the wire terminations in vertical direction for 10 s.	ΔR ± 15%
Voltage proof	1000 V AC for one minute	Less than 1 mA
Insulation resistance	500 V DC	Over 100 MΩ
Dry heat	1000 hours at max. operating temperature for each product number	ΔR ± 20%
Damp heat	1000 hours at 40 °C and 90% humidity	
Temperature cycle (thermal shock)	10 cycles as below: 1. - 40 °C for 30 minutes 2. Room temperature for 5 minutes 3. 160 °C for 30 minutes 4. Room temperature for 5 minutes	ΔR ± 15%
Electrical load	Max. current for 1000 h at 25 °C room temperature	ΔR ± 20%

Caution

- When force is applied to the lead wire the leg connections may break or chipping may occur.
- May get hot during use. When designing the environment around the power thermistor be especially careful with lead wire connections, materials used in the direct vicinity and the layout of other electrical components.
- Do not use two or more power thermistors in a row.