



T-8 BCD COMMAND with 8 RELAY OUTPUTS.



The T-8 decodes BCD signal injected to the input, connecting the corresponding output. It accepts a multiplexed input and inhibition function. It includes indicators Leds and connection terminals.

TECHNICAL CHARACTERISTICS.

Voltage.....	12 V.D.C.
Minimum Consumption. (Inhibition Input activated).....	1,5 mA.
Minimum Consumption. (Inhibition Input deactivated).....	52 mA.
Maximum Consumption.....	55 mA.
Output Load per relay.....	5 A.
Protection against inversion polarity. (P.I.P.).....	Yes.
Sizes.....	135 x 94 x 25 mm.

POWER SUPPLY AND OUTPUTS CONNECTION.

POWER SUPPLY. The T-8 circuit had to be supplied by a 12 VDC power supply correctly filtered. We recommend you to use the FE-2 power supply, which has been developed to perfectly answer to the circuit needs. Install a fuse and a switch has it is indicated on the schedule. Both are necessary for the module's protection as well as for your own safety, as it is required by the "CE" regulations.

Connect the positive and the negative of the power supply to the respective positive and negative terminals of the module, indicated in the wiring map. The distance between the power supply and the module has to be as short as possible (max. 60 cm). Verify that the assembly is correct.

Note. Connections indicated as 230 VAC in the wiring map have to be connected to 110 VAC. in Americans countries. Cebek's Modules and/or transformers will be supplied with corresponding modifications for their connection in these countries.

OUTPUT CONNECTION. LOAD. The T-8 output is controlled by a relay, and accepts any device up to 5 A. The relay is not a component supplying voltage but its function is limited to accept or deny the voltage passage like a standard switch. For this reason, you have to supply the load through this component.

The relay has three output terminals: The normally open quiescent (NO), the normally closed quiescent (NC) and the common. Install it between the Common and the NO in accordance with the schedule "Output Connection. Load". For the inverse function you have to place the load between the NC and Common.

12 V. D.C. CONNECTION

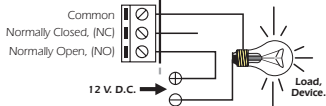

230 V. A.C. CONNECTION

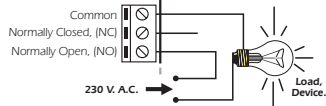

INFORMATION ABOUT THE OUTPUT. During the operating mode and according to its load, it could happen a fluctuation or an incorrect working of the output. In such case, you have to install an anti-spark circuit, (100nF/400 V Capacitor Type X2 and 47Ω 1/2 W. resistor) between both contacts of the used relay, as it is indicated on the drawing.

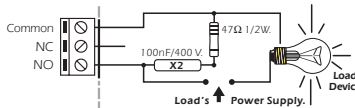

OPERATING MODE.

BCD INPUT. The circuit's control had to be done thanks a four Bits BCD input. The A input will correspond to the lesser weight (LSB), and the D input corresponds to the higher weight (MSB). You can connect each one of these eight inputs to the circuit's positive or negative, allowing you to make eight different combinations, each one activating a relay. See Fig. 1.

Fig. 1. Inputs Binary Value.

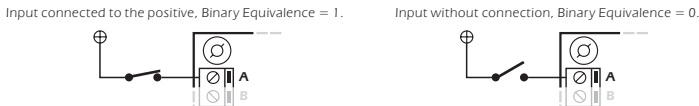

If you don't connect one input, or if you connect it to the negative, this input will adopt the "0" as binary value, and at the opposite case, if you connect it to the positive, its binary value will be "1". Connect inputs composing the binary combination adequate to the output that you wish to connect. See Fig. 2.

As default, when there is any input connected to the positive, on the circuit it is established the combination that activates the output 1. In order to activate another relay, do the corresponding combination. The selected output will be connected till you change again the inputs' connection. The injected BCD signal to the input can be generated thanks to the connection of switches, pre-selectors, push buttons, etc.... Nevertheless, you always have to insert a 12 V DC signal. More over, if you don't use the same power supply for both circuits, you have to connect negatives of this signal to the circuit. If you use the same power supply, this connection isn't necessary. See Fig. 3.

Fig. 2. Binaries Combinations for Outputs connection

Inputs	A	B	C	D
Output 1	0	0	0	0
Output 2	1	0	0	0
Output 3	0	1	0	0
Output 4	1	1	0	0
Output 5	0	0	1	0
Output 6	1	0	1	0
Output 7	0	1	1	0
Output 8	1	1	1	0

Fig. 3a. How to connect a Pre-selector to module's inputs.

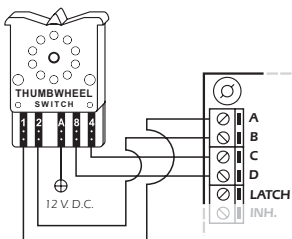
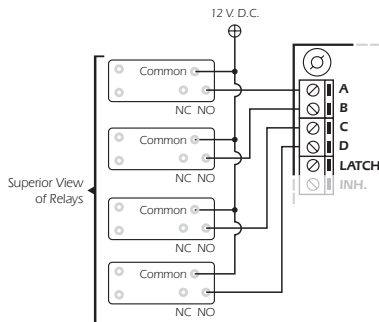

Fig. 3b. How to connect relays to module's inputs.



OPERATING MODE.

INHIBITION INPUT. As we have explained you before, when you leave inputs "opened", without connection, the combination of the first output is established, allowing in fact there is always one output activated, independently of the selected combination. To avoid this fact, you have to activate the Inhibition function. Install a switch between positive and module's inhibition input, indicated as INH. See the General Wiring Map paragraph. When you will close the switch and inject the positive on this input, the function will be activated and disconnect all outputs, without recognising signals injected on inputs. When you will open the switch and the INH input is open, the circuit will re-establish the normal operating mode.

MULTIPLEXED FUNCTION, [LATCH]. The T8 allows the multiplexed mode. This operating mode establishes thanks to an external signal, [latch], from which moment the binary signal (BCD), has to be executed on inputs. The main advantage and reason of this function is the possibility to work with different modules, using the same BCD signal for all inputs and a Latch signal for each circuit. Then, you can activate the wished output on any module, increasing the system's capacity.

To activate the Latch signal, you have to force it to the negative, connecting the Latch input to the circuit's negative. To operate in multiplexed mode, firstly you have to connect the same BCD signal to the corresponding inputs for all modules, and secondly to connect each Latch input to the common negative. Then, the BCD injected on inputs will be executed, connecting the corresponding output, only on the module where you will disconnected the Latch input.

Fig. 4. How to MULTIPLEX with two T-8.

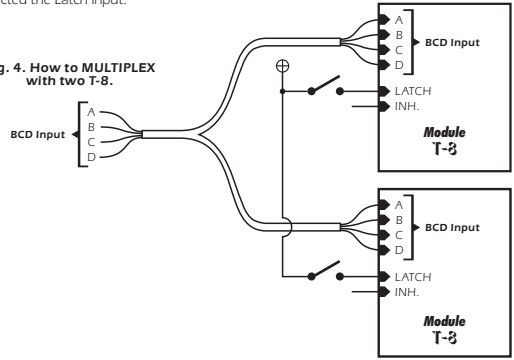

DON'T FORGET.

INSTALLATION. The cable length between BCD inputs has to be as short as possible, and from 100 cm, it is possible that you find parasites problems who will affect the module operating mode. Install the module into a metallic enclosure, and connect the negative to the enclosure chassis.

INPUTS. For other connections, don't forget that internally all BCD and Inhibition inputs have a Pull-Down resistor (connection to the negative). Also, the Latch input has an internal Pull-Up resistor (connected to the positive).

GENERAL WIRING MAP

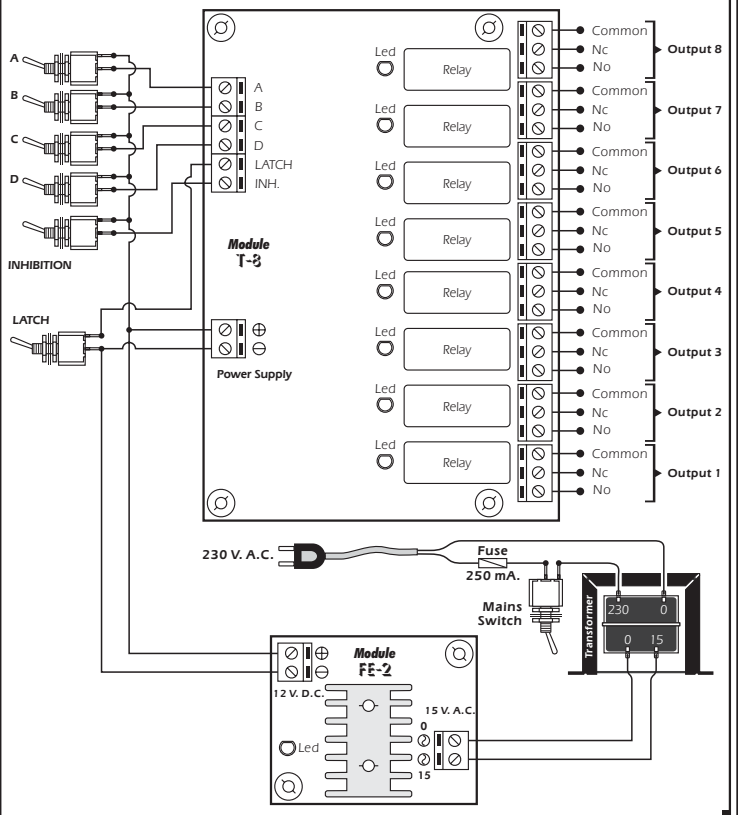

TECHNICAL CONSULTATIONS.

If you have any doubt, you could contact your wholesaler or our Technical Department.
 - E-Mail, sat@cebek.com | Fax. 34.93.432.29.95 | by mail. P.O. Box. 23455 - 08080 Barcelona - Spain.
 - Keep the invoice of this module. For any repair, the corresponding invoice had to be added. If the invoice is not presented together with this module, the module's warranty will be automatically cancelled.

All the module's CEBEK have 3 years of total warranty in technical repairing, and spaces from the date of buy.



More CEBEK module's are available in our products range, please, require our general catalogue or visit our Web side.
[Http://www.cebek.com](http://www.cebek.com)

