



Sealing Gasket



Through hole fastening

MPR-HD Series



NC3MPR-HD



NC5MPR-HD

- IP 65 - in combination with NC*FX-HD cable connectors
- Perfect for outdoor applications
- Sealing gasket for water tight panel mount
- Gold plated contacts



NC5MPR-HD

NC5FX-HD

NC3MPR-HD

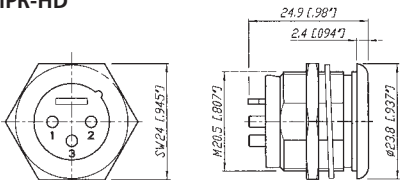

*: 3 - 5 contacts

P Series



NC3FP-1



NC6MP-B

- Male and female available in 3-6 pin configurations; 7 pin versions available in female only
- Smallest available hard wiring receptacles with large solder cups
- Male and female use different mounting hole dimensions and do not fit in same mounting hole
- Front mountable only
- One piece version – insert is NOT removable from shell
- Short female receptacle
- Compatible with Switchcraft® DxM, DxP; Cannon XLRx31, XLRx32
- 6 pole female version available with Switchcraft contact arrangement

NC3FP-1

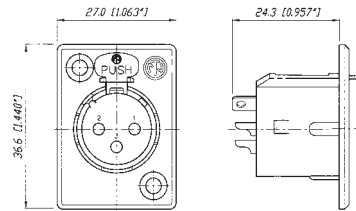

NC3MP

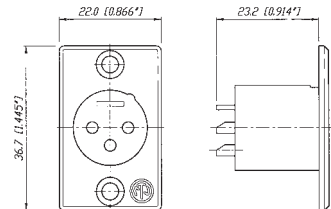

Product	
Connector Type	XLR
Gender	male
Electrical	
Capacitance between contacts	≤ 7 pF
Contact resistance	≤ 5 m Ω
Dielectric strength	1,5 kVdc
Insulation resistance	> 2 G Ω (initial)
Insulation resistance	> 1 G Ω (after damp heat test)
Rated current per contact	10 A
Rated voltage	50 V
Mechanical	
Insertion force	≤ 20 N
Withdrawal force	≤ 20 N
Lifetime	> 1000 mating cycles
Wire size	max. 1.5 mm ²
Wire size	max. 16 AWG
Wiring	Solder contacts
Locking device	latch lock
Mounting direction	front
Chassis shape	P
Material	
Contact plating	2 μ m Ag over 2 μ m Ni
Contacts	Brass (CuZn39Pb3)
Insert	Polyamide (PA 6.6 30 % GR)
Locking element	Steel Ck67
Shell	Zinc diecast (ZnAl4Cu1)
Shell plating	Nickel
Environmental	
Flammability	UL 94 HB
Standard compliance	IEC 61076-2-103
Protection class	IP 40
Solderability	Complies with IEC 68-2-20
Temperature range	-30 °C to +80 °C

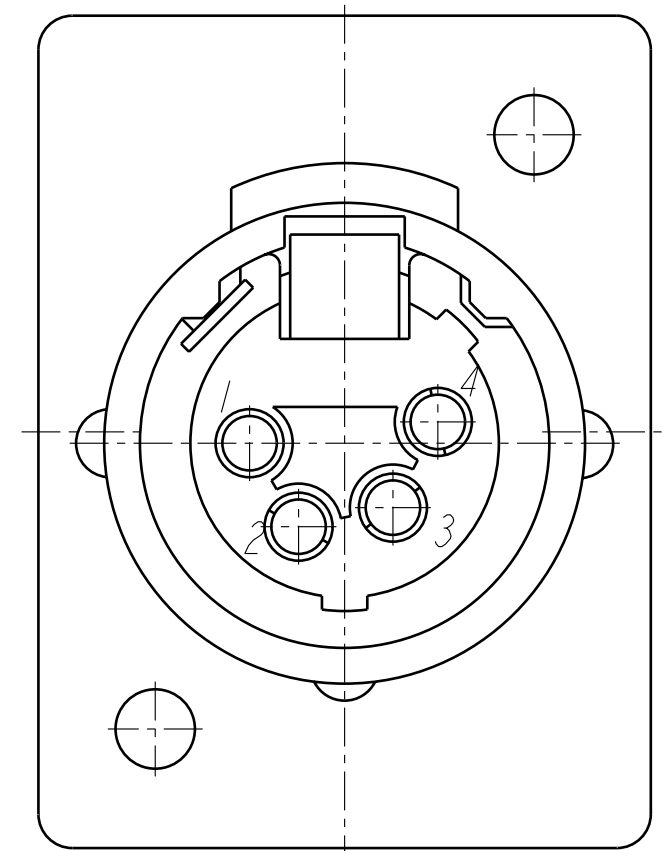
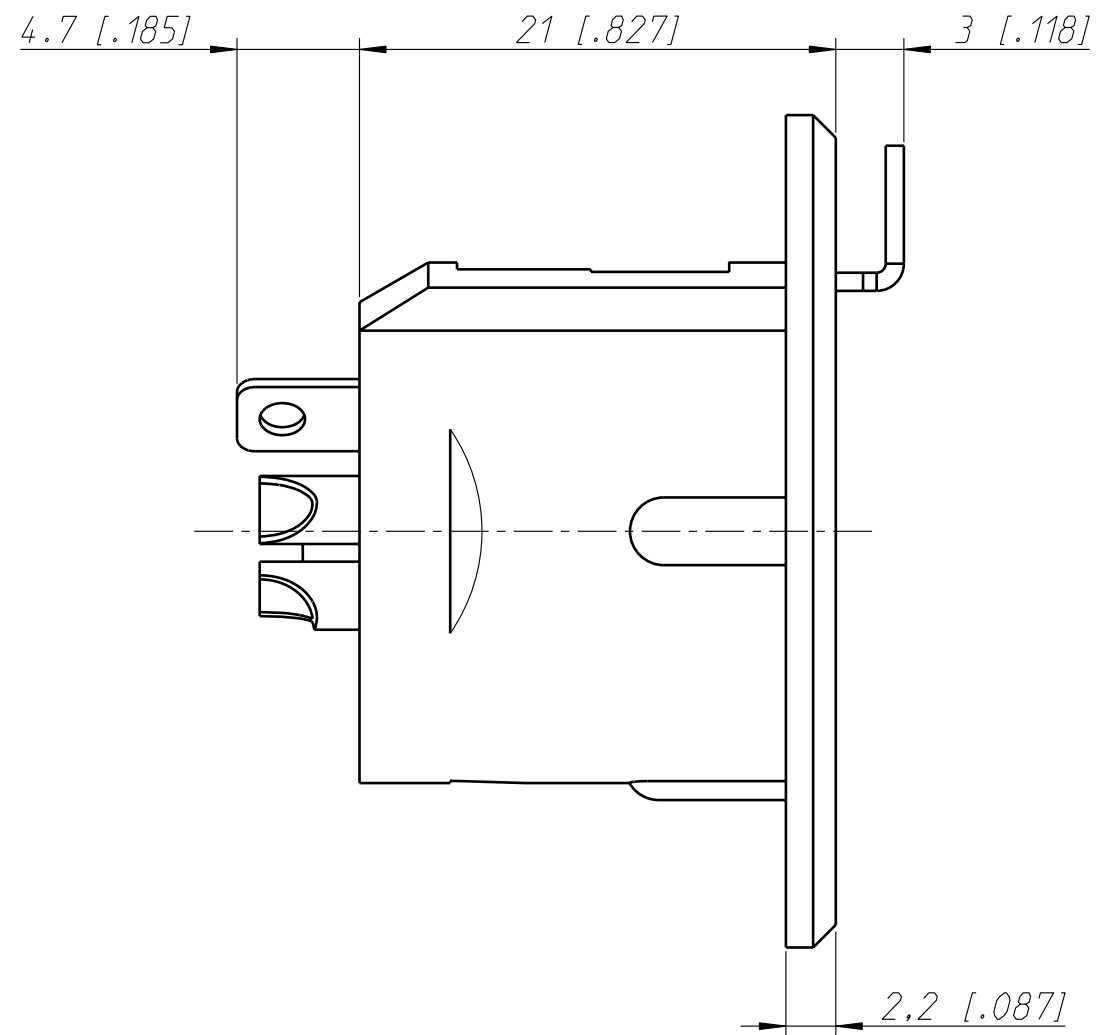
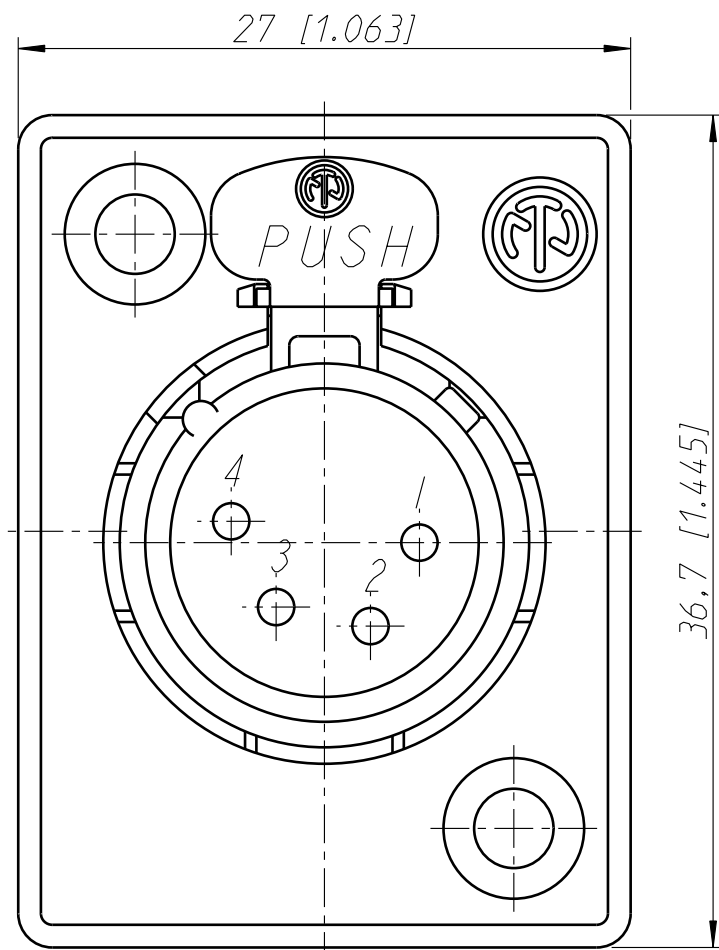

Frontplattenausschnitt (Rückseite)
Panel cut out (rear side)

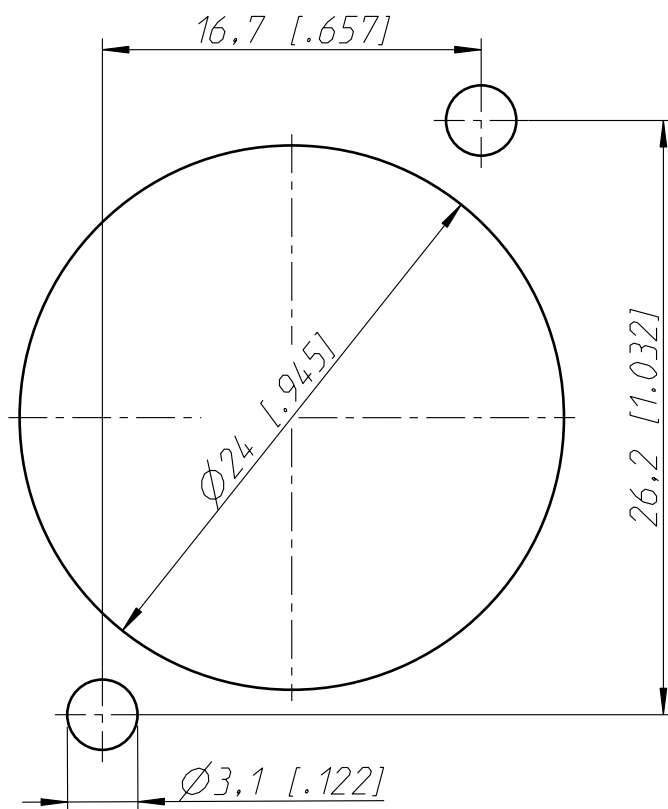

Allgemeintoleranzen ISO 2768-m	Werkstoff	Massstab: 3:1 (A3)	Datum	Name
			Gezeichnet	06.07.89
Zeichnung urheberrechtlich geschuetzt (DIN 34) (C)			Freigegeben	
			Geaendert	19.10.10
Benennung			Aend.-Nr.	Aend.-Index B
NC4FP-1			Ersatz fuer:	Blatt 1 von 1 Bl.
NEUTRIK AG FL-9494 SCHAAN			Zeichn. Nr.	ST-NC4FP-1