



I-37

TIMER FROM 2 Min. to 45 Min.

When you will connect the I-37 module's power supply, thanks to the potentiometer inserted in the PCB a delay function adjustable between 2 and 45 min start. After the adjusted time, the output will be activated up to the power supply's disconnection.
It could be activated supplying voltage and/or closing its contacts using a push button. It includes a protection against polarity inversion, an indicator operating led, connector to withdraw the exterior potentiometer and terminals to connect it.

TECHNICAL CHARACTERISTICS.

Voltage	12 V. D.C.
Minimum Consumption	15 mA.
Maximum Consumption	70 mA.
Minimum Time	2 min.
Maximum Time	45 min.
Maximum Load At The Relay	5 A.
Operating Indicator led.....	Yes.
Protection Against Inversion Polarity	Yes.

OPERATING.

POWER SUPPLY. The I-37 circuit had to be supplied by a 12 VDC power supply well filtered. Do not use suppliers or rectifiers because they allow interference's disturbing the circuit operating.
Then, we recommended you the FE-2 power supply which has been developed to perfectly answer to the circuit needs (or 12V battery for mobile application). Connect the positive of the power supply to the positive terminal indicated in the wiring map, then connect also the negative of the power supply to the negative terminal indicated in the circuit. **Verify** that the assembly has been correctly done.

TIMERING. To adjust the delay time to allow the output activation, use the potentiometer inserted in the PCB. Start the operating test placing the potentiometer at the minimum; then you could adjust it according to your need. Once the time selected, supply the I-37, and the module will be activated and start the delay function. When this last is finish, the led will light connecting the output. This output will be activated until you disconnect the power supply.

OUTPUT. CONNECTION OF THE LOAD. The output Module (I-37) is controlled by a relay, allowing any load until 5 A. as maximum consumption. The relay has 3 output terminals the normally open at quiescent (NA), the normally closed at quiescent (NC) and the common. The operating of this mechanism is the same as a switch with two (2) terminals NA and common, if you wish that the output will be activated during the timer, or between the NC and the common to obtain the reverse operating.
In the Output connection paragraph, you could appreciate the typical connection for a devices operating at 12 VDC and to operate at 220 VAC.
The installation is between the Common and NA, where the device or load that you wish to control will be activated during the operating time.
To obtain the inverse operating, substitute in the connection the NA by the NC.

START BY PUSH BUTTON. The I-37 module could be activated closing its contacts using a push button or supplying voltage (as deliver from our factory). To activated the I-37 module using push button, you have to withdraw the **C3** capacitor indicated in the General wiring map and in the PCB. Then, install a Quality push button to the piece terminals or J2 jumper, also indicated in the General wiring map. If the distance to connect both parts, you have to use shielded cable. Activating the push button, the delay time will start and at the end, the relay will be activated. To stop it, you have to disconnect the power supply.



TIMERS

Ref. FULL9805_Ang.

I-37

OPERATING.

EXTERIOR INSTALLATION OF THE POTENTIOMETER. If you wish to withdraw or substitute the potentiometer inserted into the P.C.B by an exterior one, firstly you had to suppress the already soldered potentiometer. Then, and as it is indicated in the drawing, connect the cable between the element or jumper indicated as "J1" up to the new potentiometer. This potentiometer had to be lineal and offering 4M7.

GENERAL WIRING MAP.

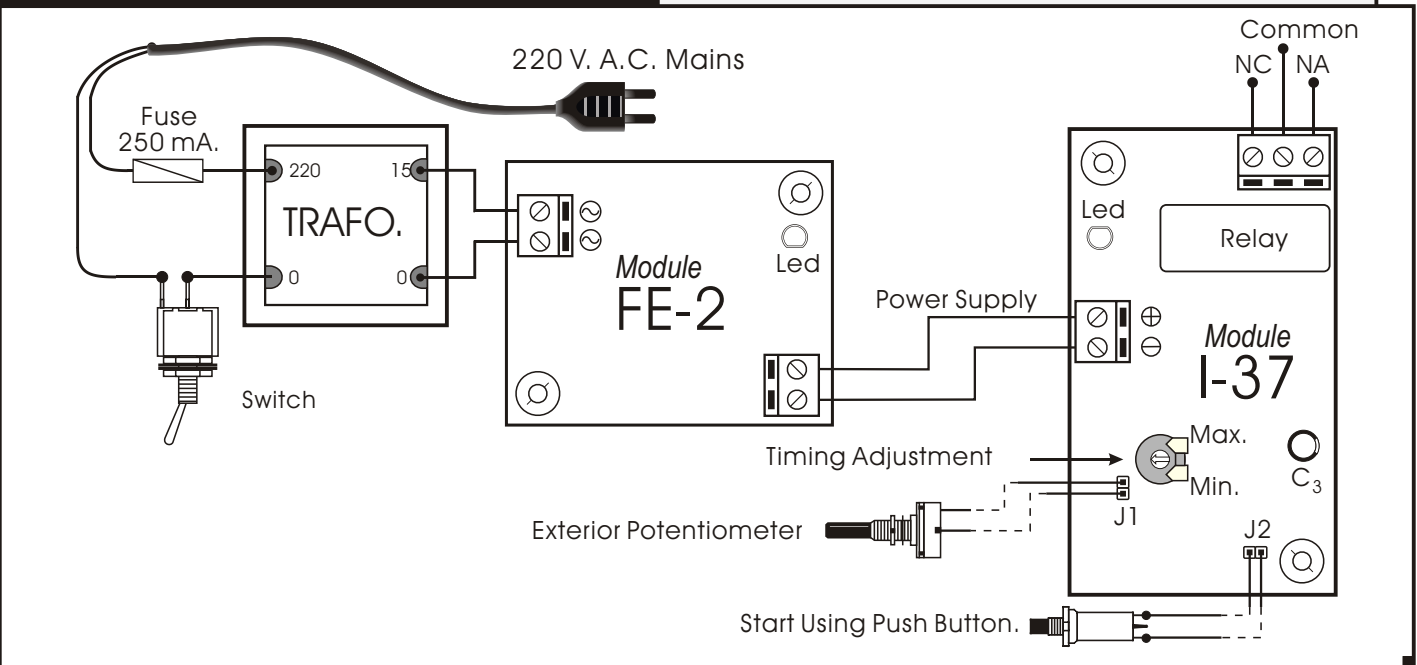

OUTPUT/LOAD CONNECTION.

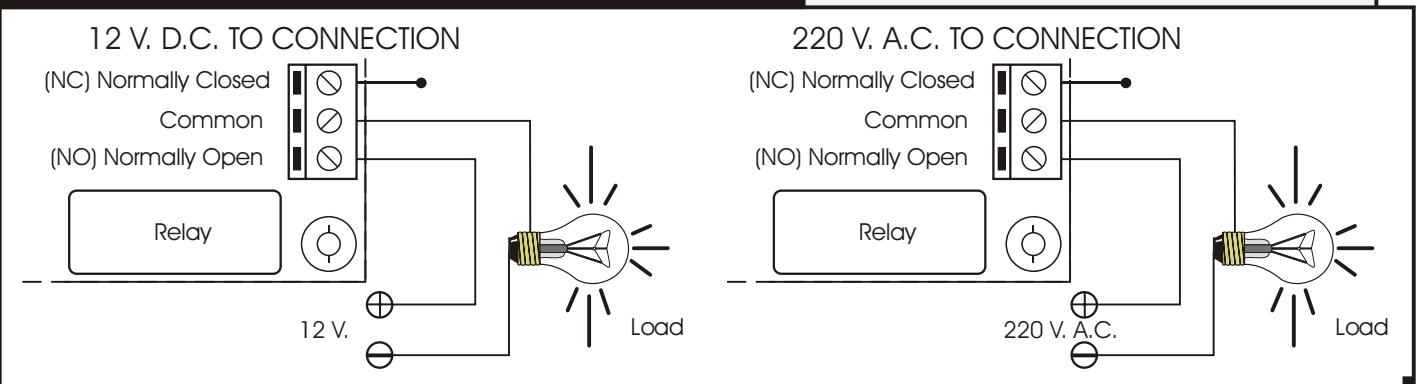

TECHNICAL SUPPORT AND INFORMATION.

For any questions or more information:

By Fax. (24h.) +34.3. 432.29.95

By Mail: C/ Quetzal, 17-21, Entlo. 2º (08014) BARCELONA - SPAIN.

By E-Mail: cebek@sakma.es

Keep you invoice. For any repairing could you send this with module. Else, the module will lost the warranty.

**MORE 300
MODULES.**

All the module's CEBEK have **3 years of total warranty** in the technical repairing, and spares from the date of buy.

CEBEK is trade make of FADISEL S.L. more than 300 module's are available in stock for any purpose **request our CATALOGUE**, or visit our Web.

[Http://www.sakma.com/CEBEK](http://www.sakma.com/CEBEK)

WARRANTY

**3
YEARS**